



TAI-SAW TECHNOLOGY CO., LTD.

No. 3, Industrial 2nd Rd., Ping-Chen Industrial District,
Taoyuan, 324, Taiwan, R.O.C.

TEL: 886-3-4690038 FAX: 886-3-4697532

E-mail: ttsales@mail.taisaw.com Web: www.taisaw.com

Approval Sheet For Product Specification

Issued Date: 12/17/2002

Product Name: SMD7x5 12MHz Crystal Resonator

TST Part No.: TZ0144A

Customer Part No.: _____

Company: _____

Division: _____

Approved by : _____

Date: _____

Checked by: _____ Robert Chang

Approved by: _____ TF Yang / Mark Chen

Date: _____ 12/17/2002



TAI-SAW TECHNOLOGY CO., LTD.

No. 3, Industrial 2nd Rd., Ping-Chen Industrial District,
Taoyuan, 324, Taiwan, R.O.C.

TEL: 886-3-4690038 FAX: 886-3-4697532

E-mail: tstsales@mail.taisaw.com Web: www.taisaw.com

SMD7x5 12MHz Crystal Resonator

MODEL NO.: TZ0144A

REV. NO.: 3.0

RoHS Compliant
Lead free
Lead-free soldering

Electrical Specifications:

	Specification
Nominal Frequency	12.0 MHz
Mode of Vibration	Fundamental
Storage Temperature Range	-50°C to +125°C
Operating Temperature Range	-10°C to +60°C
Frequency Stability over Operating Temperature	+/-30 ppm
Frequency Make Tolerance	+/-30 ppm @ 25°C +/- 3°C
Resonance Resistance(R)	40 Ω max.
Shunt Capacitance (Co)	7 pF max
Drive Level	100 uW nominal
Load Capacitance-CL	18.0 pF
Aging	+/-3.0 ppm/year @25°C
Marking	Laser marking
Insulation Resistance	500M Ω min at DC 100V

Mechanical Dimensions (mm):	Marking:
	<div style="border: 1px solid black; border-radius: 15px; padding: 10px; text-align: center;"> <p>12.000</p> <p>144ⓉZD</p> </div> <p>“Z” is product code “D” is date code</p>

PACKING:

1. REEL DIMENSION (Unit: mm)

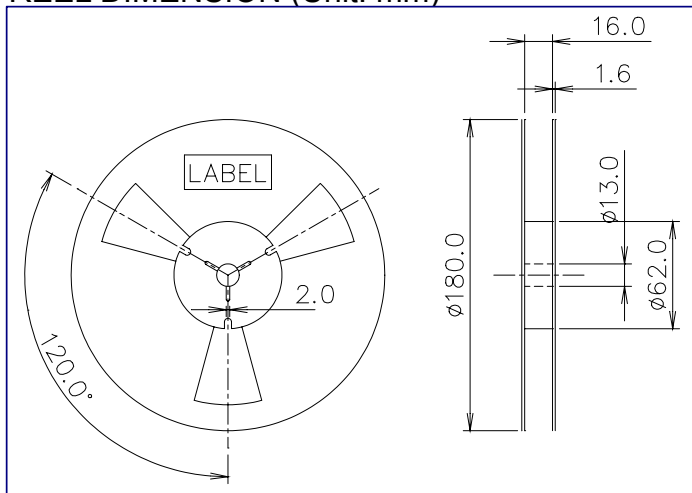

2. TAPE DIMENSION (Unit: mm)

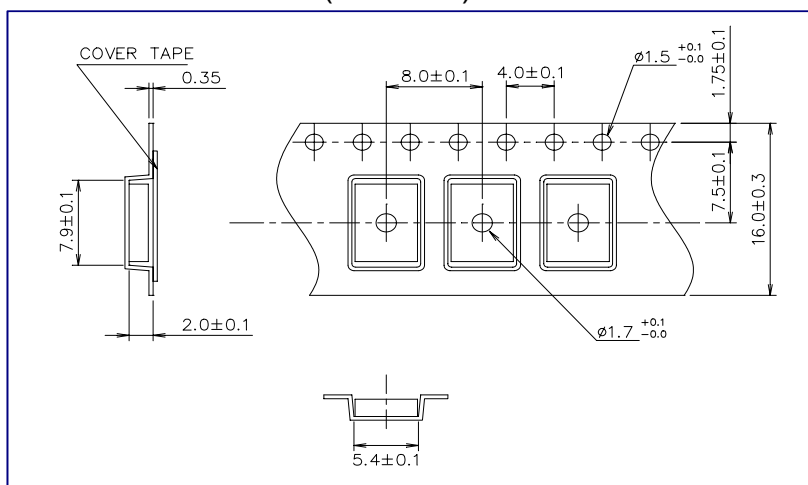

3. PACKING DIRECTION

The dot or the logo of marking should be close to the hole of tape.

Product Code Table

Year	2001	2002	2003	2004
	2005	2006	2007	2008
Product Code	Z	z	<u>Z</u>	<u>z</u>

Date Code Table

WK01	WK02	WK03	WK04	WK05	WK06	WK07	WK08	WK09	WK10	WK11	WK12	WK13
A	B	C	D	E	F	G	H	I	J	K	L	M
WK14	WK15	WK16	WK17	WK18	WK19	WK20	WK21	WK22	WK23	WK24	WK25	WK26
N	O	P	Q	R	S	T	U	V	W	X	Y	Z
WK27	WK28	WK29	WK30	WK31	WK32	WK33	WK34	WK35	WK36	WK37	WK38	WK39
a	b	c	d	e	f	g	h	i	j	k	l	m
WK40	WK41	WK42	WK43	WK44	WK45	WK46	WK47	WK48	WK49	WK50	WK51	WK52
n	o	p	q	r	s	t	u	v	w	x	y	z